

Timer Mode

The system can be made to automatically play at preset, fixed intervals. This is called the Timer Mode which is configured by using "Txx" for the configuration letters, where "xx" is a two digit number specifying the interval in minutes. For example, "T60" sets the interval to 60 minutes, so the system will automatically play a file every 60 minutes, starting from file 001.

Although the Timer Mode does not require manual triggering, you can still manually trigger the system when it's idle. In the idle period, the system works as if it's in the DNC mode. After the system fulfills the manual triggering, the idle period resets (restarts from the beginning).

Q Mode

The Q mode is disabled by default, and enabled by adding a letter Q as the fourth letter in the configuration file MODE.TXT. In the Q mode, the left channel output is inverted. For stereo files this creates a virtual surround. For mono files this creates a more powerful differential output, but the speaker (8 Ohm recommended for this mode) must be connected to the LEFT and the RIGHT terminals (instead of the LEFT and the COMMON terminals).

Battery Mode

To save battery life, move the jumper from J1 to J2 on the circuit board, and tie the TRG (trigger) and the BSY (busy) terminals together with a piece of wire. Now both terminals become the trigger input while the busy output is no longer available. In this mode the whole board is powered down until it's triggered, resulting in maximum power saving. Please note that there are a few drawbacks:

- There will be some noise before and after the playback as the unit powers up and down.
- Only the following modes are supported: DNC (default), DNCQ.

Random Play

Random Play can be achieved by using either the DIC mode (for normally open input) or the DIO mode (for normally closed input.) The randomness is actually created by the variation in the duration of the momentary opening or closure of the contacts. For example, pressing a normally open push button in the DIC mode will apply a continuous trigger to the unit, causing it to start playing. But as soon as the file starts to play, it gets interrupted by the continuous trigger so the next file starts to play. This process goes on and on until the push button is released. At that moment, the unit starts to play whichever file it happens to land on.

Random Play is not available when the unit is in the Timer Mode.

Trouble Shooting

No audio.

1. Files must be numbered (see the File Numbering section), and file 001 must exist.
2. File type must be MP3 - other types are not supported.
3. System configuration (MODE.TXT) may be incorrect.
4. Try turning up the volume.

Does not play the next file.

Files must be numbered consecutively. For example, if files are numbered 001, 002 and 004 then 004 will never be played since 003 is missing.

Popping noise before/after the playback.

This is normal for systems working in the Battery Mode.

EM21C User's Manual

Technical Specifications

Audio Quality

CD quality (mono/stereo)

Max. Output Power

6W per channel stereo (12V supply, 4 Ohm load, 10% THD+N)
8W mono (Q mode, 12V supply, 8 Ohm load, 10% THD+N)

Supported File Types

MP3 (ISO 11172-3 up to 44.1KHz)

Trigger Input

One input for push button, motion sensor, or DC control voltage

Max. Number of Sound Files

99

Flash Card Type

Both SD (FAT16) and SDHC (FAT32) cards are supported
* Mini and micro SD cards are also acceptable with adaptor

Max. Flash Card Capacity

2GB for SD, 32GB for SDHC

Max. Recording Time

About 34 hours of 128Kbps MP3 audio on a 2GB SD card
About 544 hours of 128Kbps MP3 audio on a 32GB SDHC card

Supply Voltage

10 ~ 15 VDC regulated

Typical Standby Current

< 1mA for the battery mode, 120mA otherwise

Physical Dimensions

3.1" x 2.8" x 1.3" (excluding mounting ears)

Firmware Revision

1.3

Typical Wiring Diagram

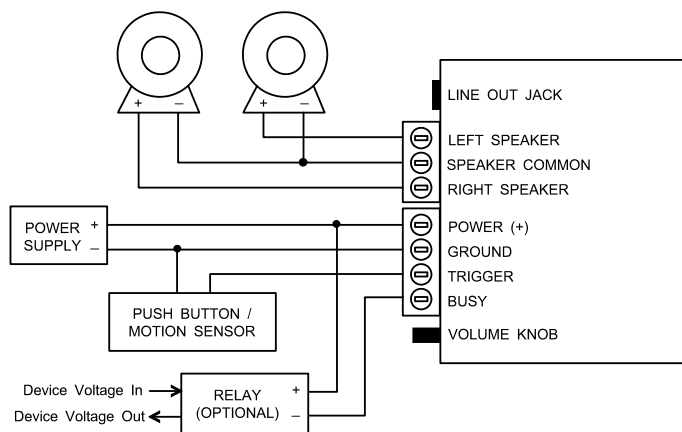

Line Out Jack

This 3.5mm phone jack provides single ended output for headphone or power amplifier.

Speaker Outputs

The speaker outputs are single ended. Load impedance is 4 to 8 Ohms.

Power & Ground

Be sure the supply voltage is within the specifications or the unit may be damaged.

Trigger Input

Depending on the operation mode, the playback is activated by making or breaking the contact between this input and the ground.

Busy Output

This open collector output is activated during audio playback, capable of sinking up to 100 mA of current. This output can be used to turn on an external relay/solenoid that further controls devices such as motors and lamps. The busy output is not available when the system is configured for the Battery Mode.

Volume Knob

Turn the knob clockwise to increase the output level. It affects both the speaker output and the line out.

SD Card

Both SD (FAT16) and SDHC (FAT32) cards are supported. Files on the flash card should be properly numbered (see the File Numbering section). Be sure to turn the unit off before inserting the card or the system may not work. To remove the card, push it again.

File Numbering

Sound files must be numbered uniquely and consecutively starting from 001, even if there is only one file. The 3-digit file number must be added in front of the original filename, e.g. "001 Anyname.mp3". Files are played in ascending order. The first trigger plays file 001, the second trigger plays file 002, and etc. If the next number is missing, the playback sequence restarts from file 001 which must always exist.

System Configuration

The system can be easily configured with a simple text file called MODE.TXT on the flash card. If there is no MODE.TXT on the flash card, the system will operate in the default mode "DNC". Only three capital letters are needed in the MODE.TXT file.

First Letter: D

Second Letter: N, I or H

N: Non-interruptible

The file is played once per trigger and the playback is non-interruptible.

I: Interruptible

The file is played once per trigger but the playback is interruptible by a new trigger.

H: Holdable

The file is played for as long as the trigger is present. If the trigger is still present at the end of the file, the next file will start to play.

Third Letter: C, O, M or B

C: Close

Trigger is continuously present for as long as the input is closed (tied to ground), e.g. while a ground connected push button is pressed down.

O: Open

Trigger is continuously present for as long as the input is open, e.g. while a ground connected push button is not pressed down. This option is often used with motion sensors with normally closed contact - playback starts when the contact opens (motion detected).

M: Make

A single, momentary trigger is generated when the input switches from open to close, e.g. when a ground connected push button is being pressed down.

B: Break

A single, momentary trigger is generated when the input switches from close to open, e.g. when a ground connected push button is being released.

Configuration Examples

DNC - Play the file uninterruptible when the input is closed. If the input is still closed at the end of the file, the next file will start to play.

DNM - Play the file uninterruptible when the input is closed. If the input is still closed at the end of the file, the next file will not start to play. To play the next file, the input must open then close.

DHO - Play the file for as long as the input is open. If the contact is still open at the end of the file, the next file will start to play.

DIM - Play the file when the input switches from open to close. During playback, if the input switches from open to close again, stop immediately and starts to play the next file.

DHM, DHB - These modes are invalid because Make/Break is momentary (not holdable).

DIC, DIO - These modes will set the system to random play (see the Random Play section).

Background Music (firmware version 1.3 and higher)

If there is a file called "000.mp3" on the flash card, the system will automatically starts to loop-play it as background music. The background music will be interrupted immediately when a valid trigger signal is detected.